

The logo for MICROSTAR, featuring a red triangle to the left of the word "MICROSTAR" in a bold, black, sans-serif font.

**MODEL 320-185 HS  
HIGH SPEED 5-AXIS CMM**

**POWERFULLY QUICK 3D Metrology Frame**

**RAPID 5-Axis PH20 Probe System**

**Cut Cycle Times in Half**

**Infinite Probe Positioning**

**Autonomous Head-tap Measuring**

**Automatic Stylus Changing**

**CAD Programming Online or Offline**

**Best Support in the Industry**

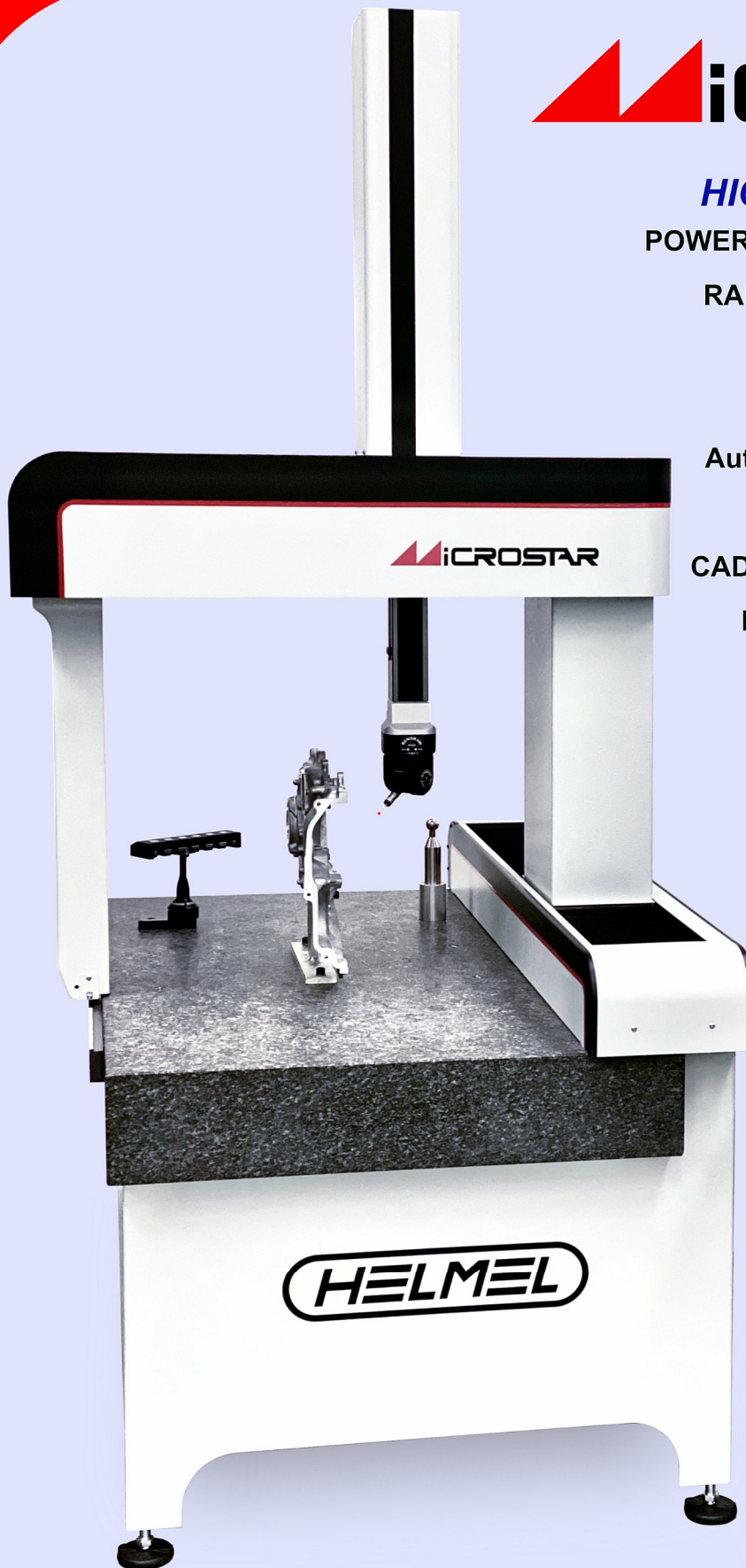

**HELMEL**

**made in usa**



## MODEL 320-185 HS HIGH SPEED 5-AXIS CMM

The MICROSTAR **320-185 HS** Coordinate Measuring Machine has been developed to take advantage of the **High Performance PH20 5-AXIS Probe**. The system is an evolution of Helmel's time-tested and thoroughly proven Microstar CMM Series of all-mechanical bearing machines with intrinsic mechanical accuracy. It features the PH20 **Infinite Positioning** probe concept that combines true 5-axis motion capabilities with autonomous head-tap measuring, allowing access to tight spaces and precise measurement of many features with the head only while the CMM remains stationary.

The **320-185 HS** includes Renishaw's UCCT5 5-axis controller and MCUIlite-2 Joystick. Scale resolution is super small at 0.000002" (0.05 $\mu$ m). The drive system is upgraded with strong motors and tachometers for rapid and crisp motion, and with perfectly tuned motion parameters. A taller Z-axis travel gives the probe more operating space and extra Y-axis travel leaves room for calibrations and automatic stylus changing.

The **320-185 HS** is all about speed. It is capable of increasing throughput 2-3X over conventional CMM inspection cycles. It's like getting two CMMs for the price of one. The system is suited to factory floor applications and includes Helmel's legendary reliability and durability.

The system includes:

- CMM Manager Standard CAD DCC Software System
- DXF, IGES and STEP included
- TCR20 (6) Port Stylus Change Rack
- (2) additional Stylus Modules
- Rolling Side Cabinet for Controller and High Performance PC
- Ø1" Calibration Sphere with Certification
- Starter Stylus Kit and Widget Training part
- One Year Warranty and Software Service Contract
- The best support in the industry from Helmel

Installation and training are added in Quotations.

Contact Helmel for the full range of options, accessories and training at 1-800 BEST-CMM (1-800-237-8266)

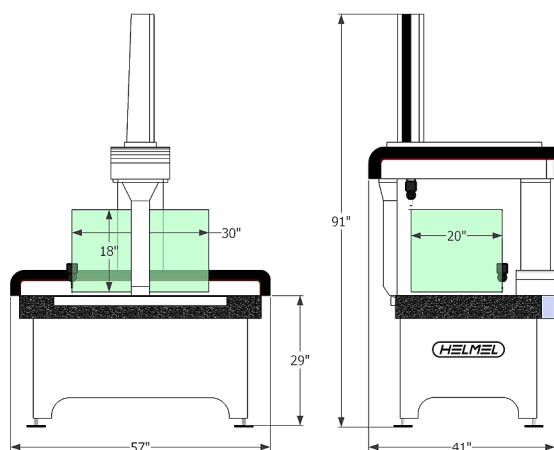
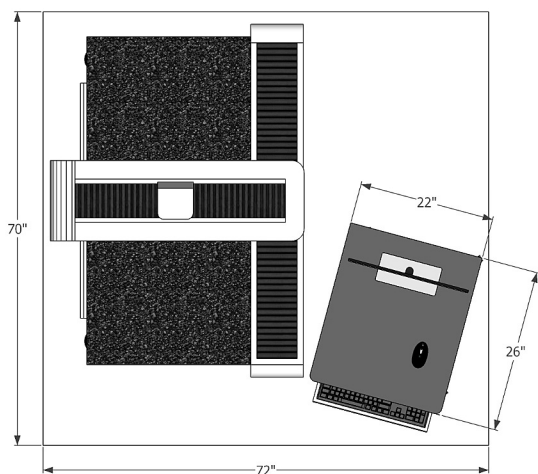
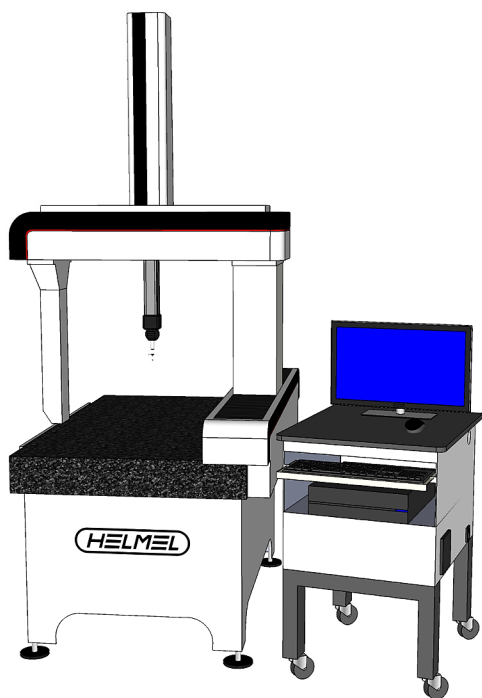

### SPECIFICATIONS (subject to Quotation)

Resolution:	0.000002"
Repeatability:	0.000060"
Linear Accuracy (X, Y, Z):	0.000060" + 0.000005"/inch
Volumetric Accuracy:	0.000380"
Utility required:	120-220V, 50-60~, 20A



www.helmel.com  
made in usa